

Data 17/03/2006

Nome file 1C43CT1

Versione A06-1

Cassettiera da inserimento

1) Applicare la cassettera mediante la viteria in dotazione facendo attenzione nel far corrispondere i fori della cassettera con quelli della fascia (come da schema)

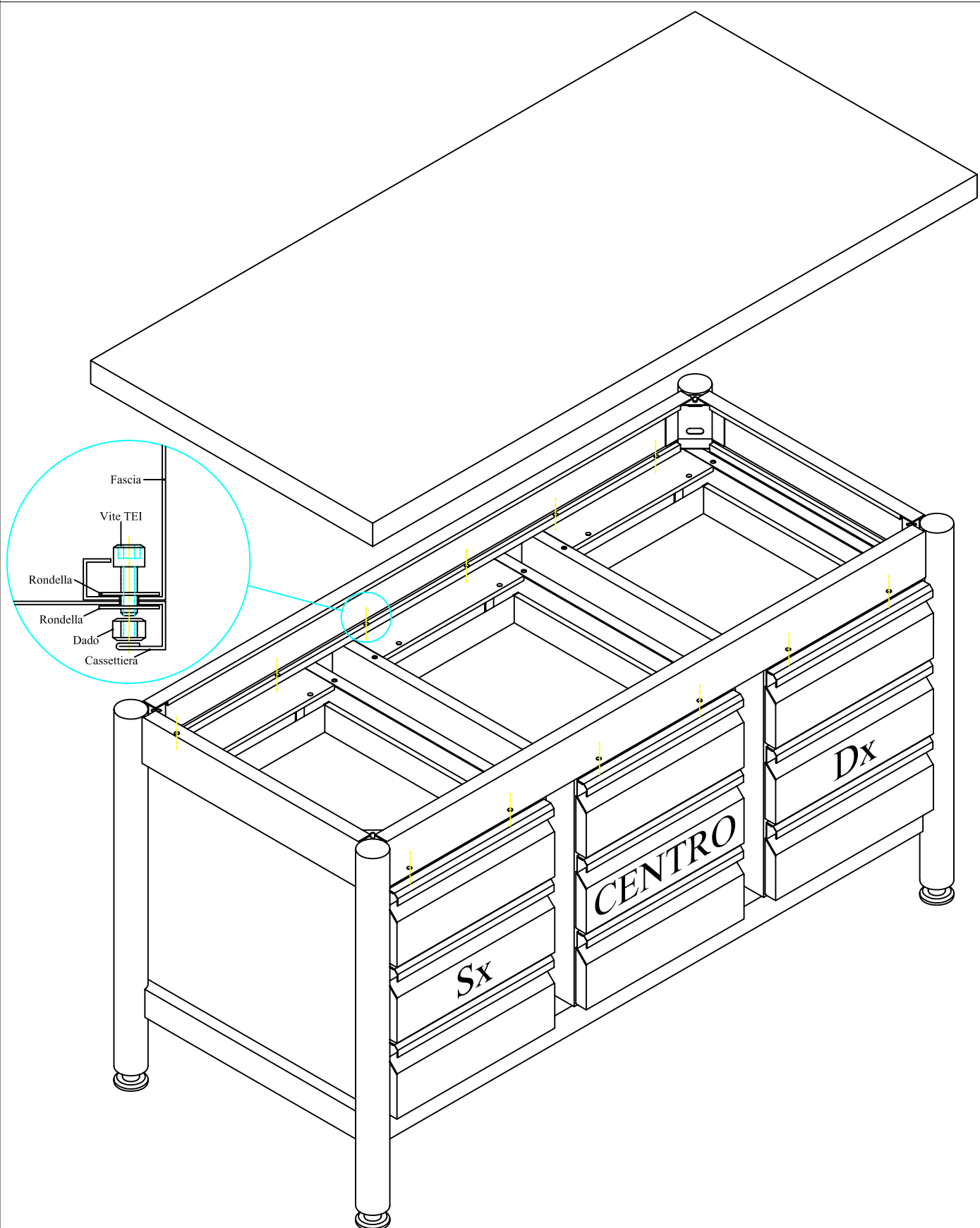

Montaggio su tavoli di profondità maggiore

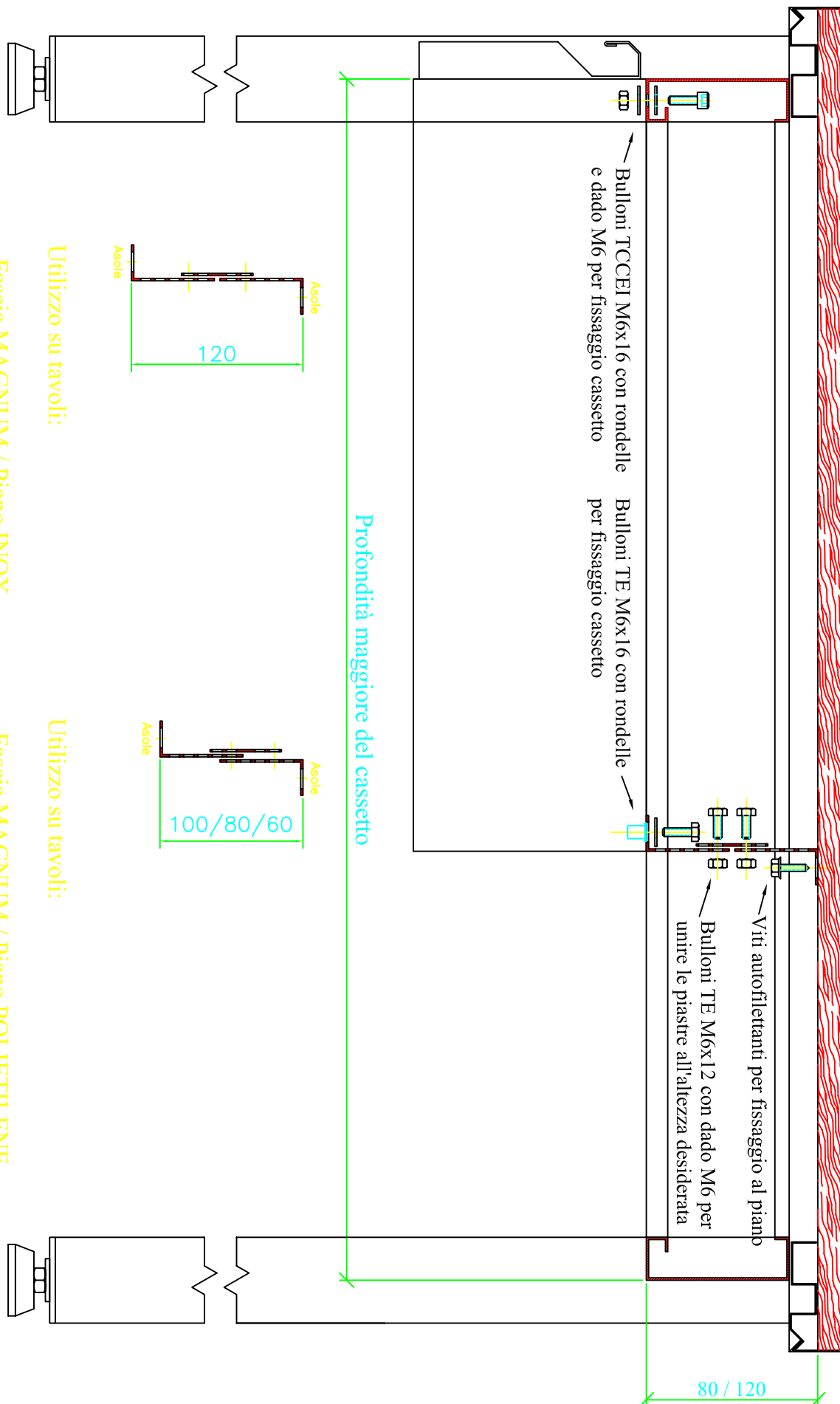

Utilizzo su tavoli:

- Fascia MAGNUM / Piano INOX

Utilizzo su tavoli:

- Fascia MAGNUM / Piano POLIETILENE
- Fascia MICRON / Piano INOX
- Fascia MICRON / Piano POLIETILENE

Date 15/04/2008

File name 1C43CT1_EN

Version A06-1

Chest of drawers to insert

1) Apply the chest of drawers using the screws supplied making attention to match the holes of the chest of drawers with the holes of the upper band (as drawing)

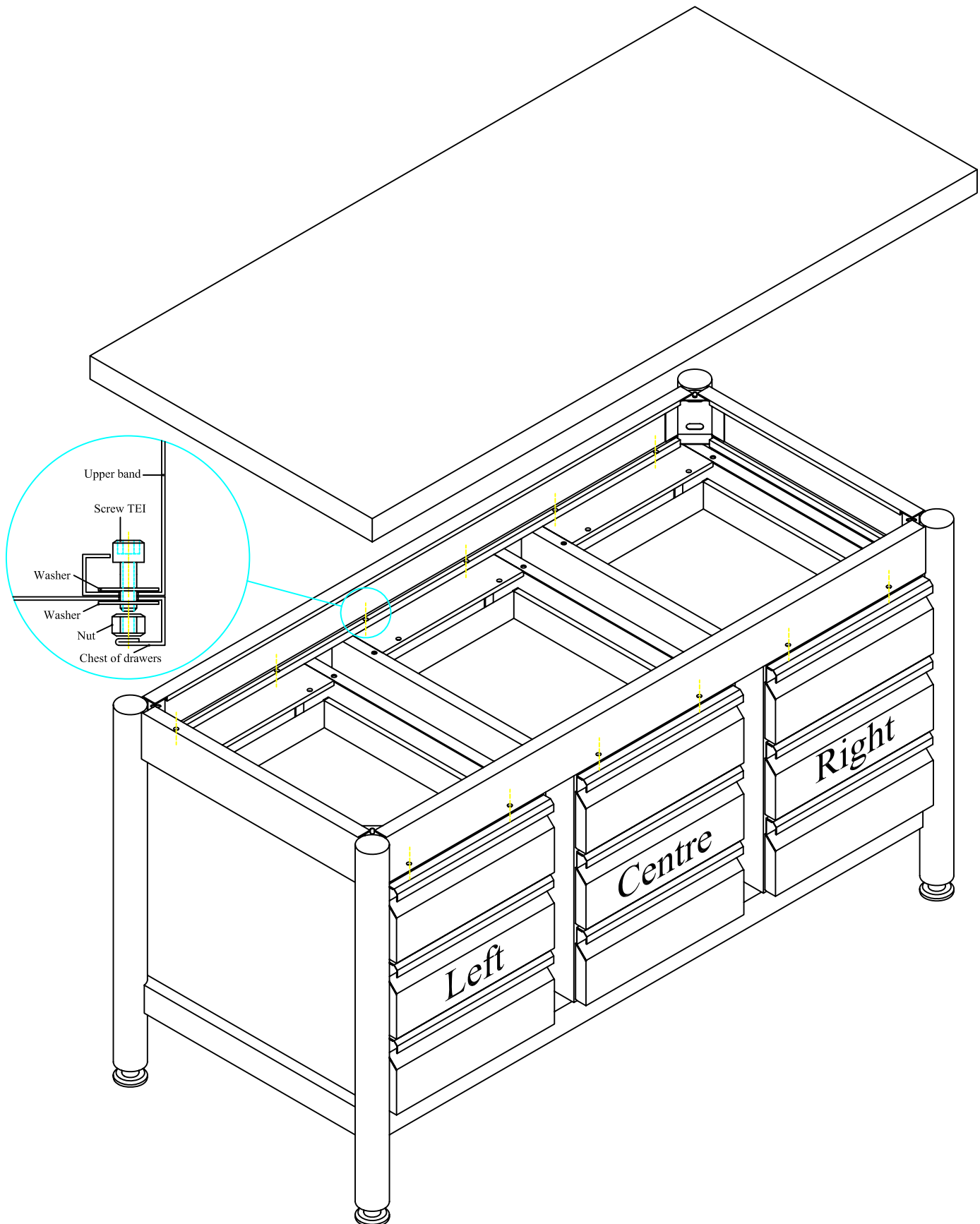

Date 15/04/2008

File name IC43CT1_EN

Version A04-1

Assembly on greater depth tables

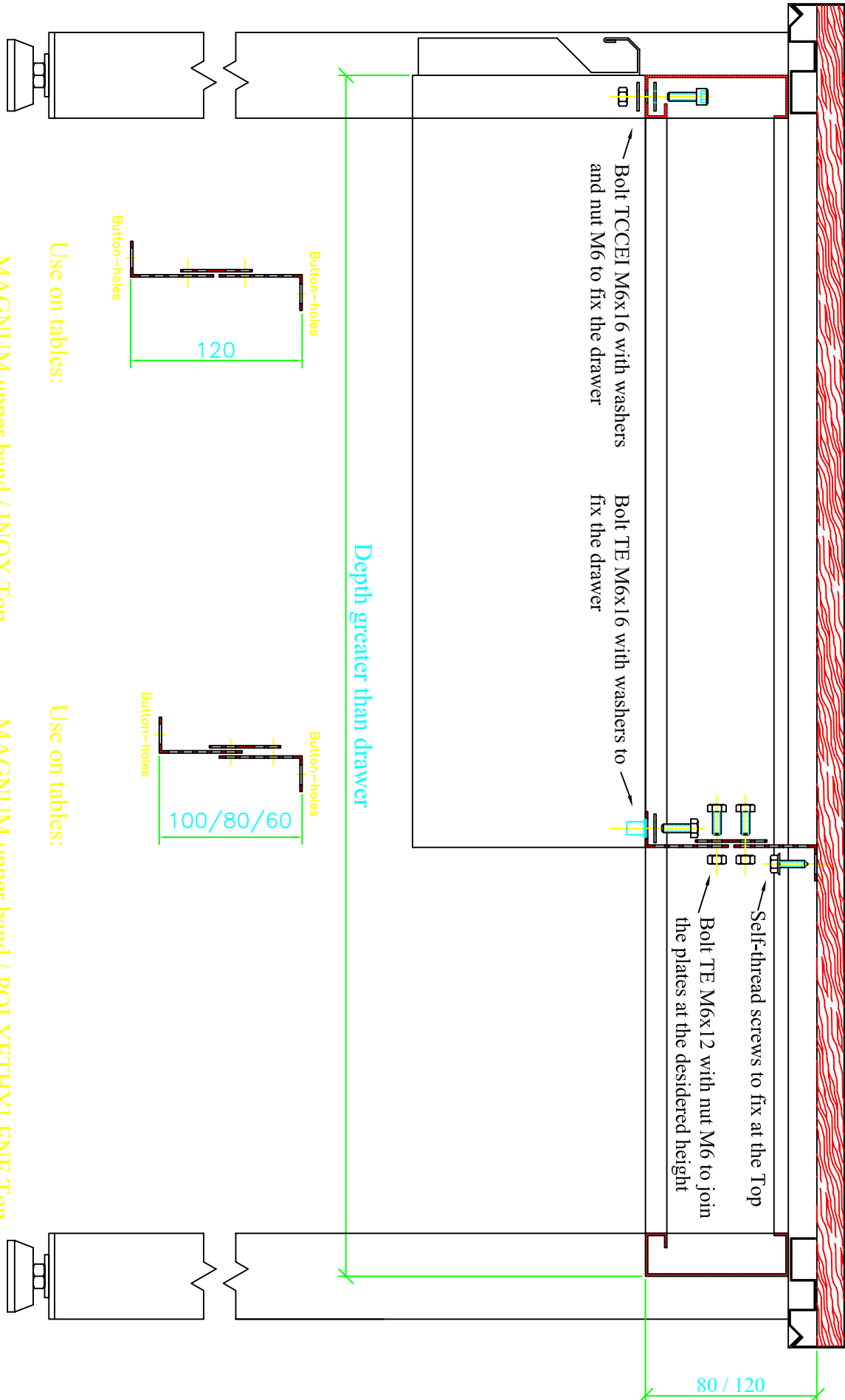

Use on tables:

- MAGNUM upper band / INOX Top

Use on tables:

- MAGNUM upper band / POLYETHYLENE Top
- MICRON upper band / INOX Top
- MICRON upper band / POLYETHYLENE Top