

Lateral view - VP 105 NV

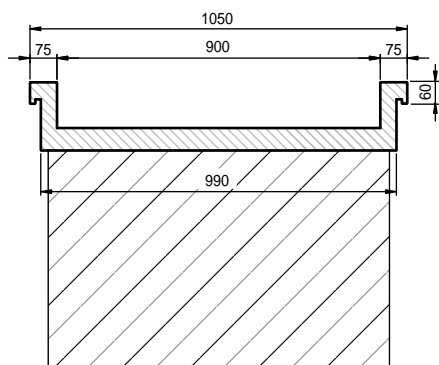

Tank - Section A:A

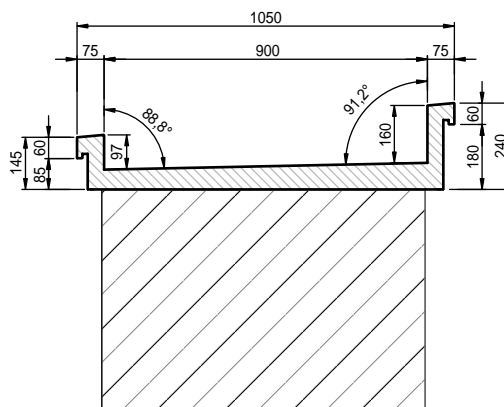

Tank - Section B:B

TECHNICAL FEATURES

Overall dimensions (mm)	1050x1175x1093h
Surface exposure (m <sup>2</sup> )	0,81

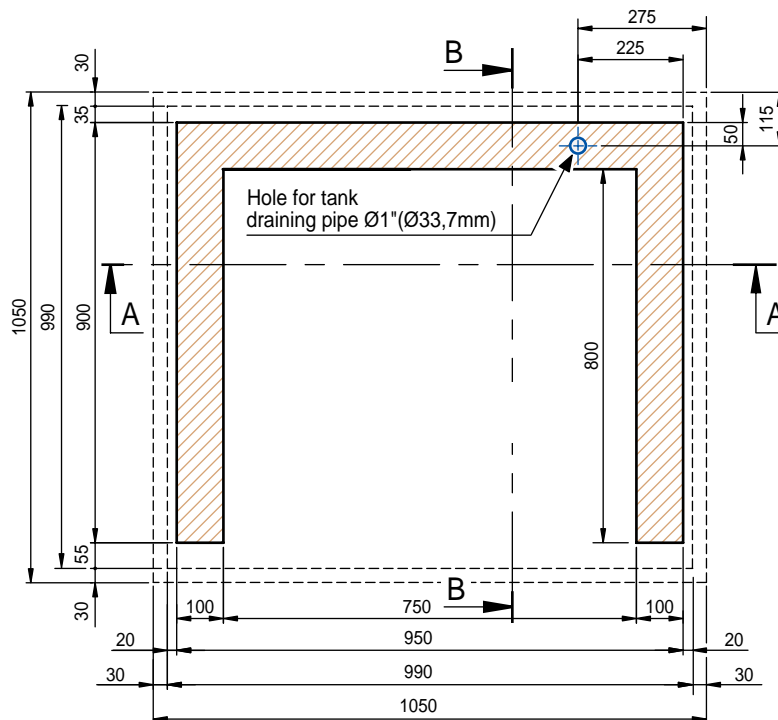

Plan view

FISH COUNTER 690 - VP 105 NV

Tank made of AISI 316 scotch-brite stainless steel with 31 mm drainage hole (3/4") supplied with internal high density polyurethane foam insulation complete with removable perforated false bottom made of stainless steel.  
 The protection on the public side is characterized by tempered glass and by shockproof bar made of stainless steel. At the sides the tank is protected by two AISI 316 stainless steel shaped edges.