

Vista laterale - VP 105 PV

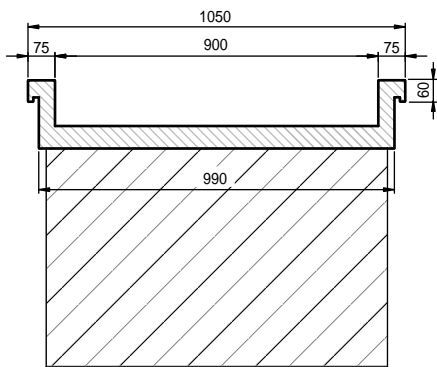

Vasca - Sez. A:A

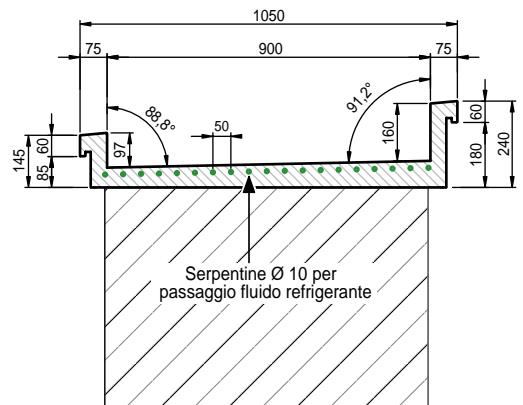

Vasca - Sez. B:B

CARATTERISTICHE TECNICHE	
Dimensioni d'ingombro (mm)	1050x1175x1093h
Suprficie esposizione (m <sup>2</sup> )	0,81
Gas refrigerante	R404A

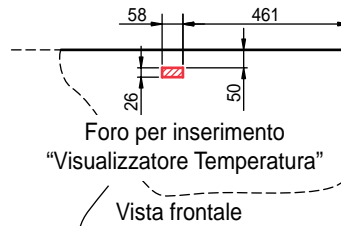

Vista frontale

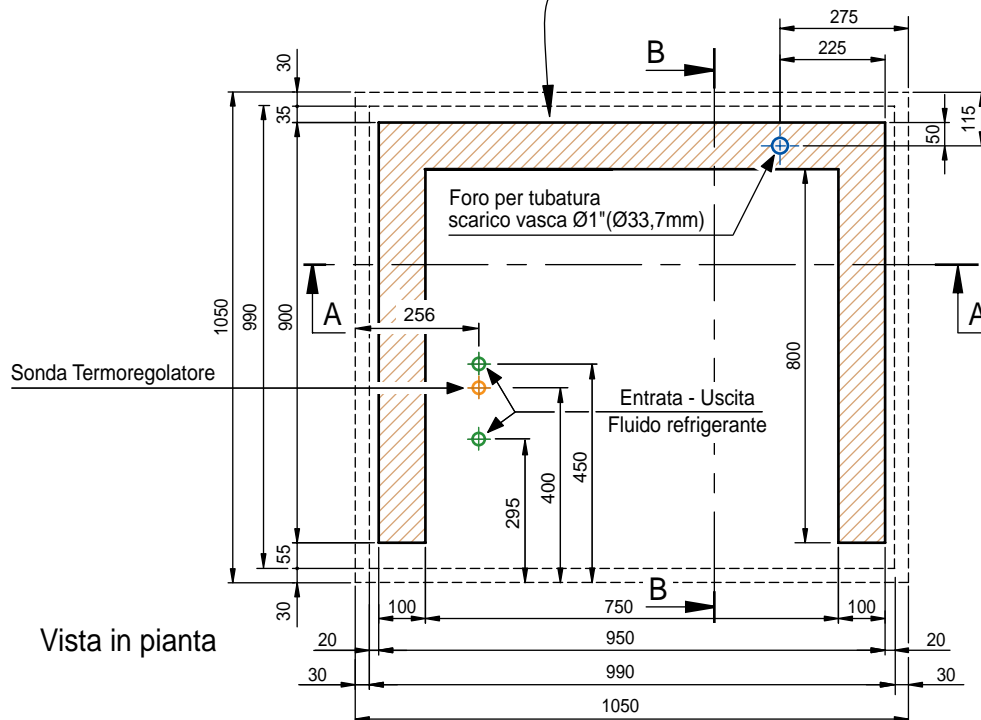

Vista in pianta

BANCO PESCE 690 - VP 105 PV

Vasca in acciaio inox AISI 316 scotch-brite con foro di scarico di mm 31 (3/4") fornita con isolamento ottenuto tramite schiumatura interna in poliuretano ad alta densità e completa di falso fondo forato asportabile in acciaio inox. La vasca è fornita completa di termometro elettronico digitale, con display di visualizzazione temperatura posto sul lato pubblico. La protezione sul lato pubblico è caratterizzata da un vetro temperato e da una barra antiurto in acciaio inox. Lateralmente la vasca è protetta da due spondine sagomate in acciaio inox AISI 316.

Emissione:	30/05/2008
Revisione:	0
Foglio	1 di 1

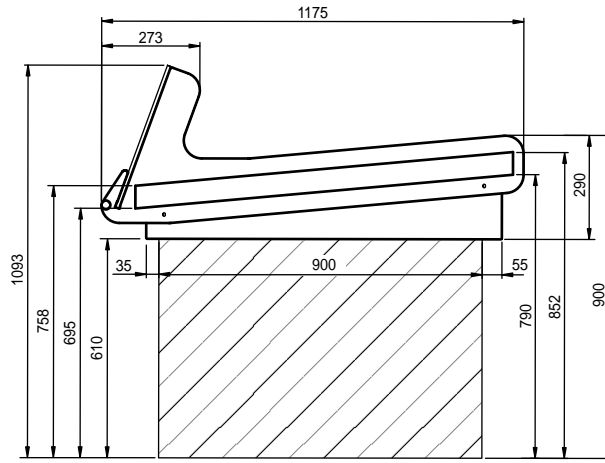

Lateral view - VP 105 PV

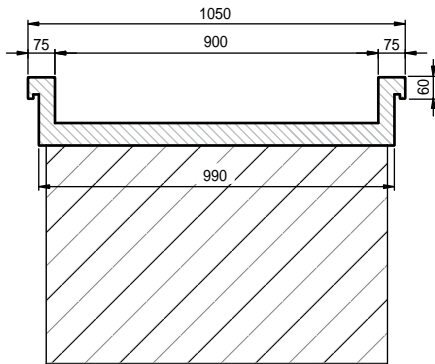

Tank - Section A:A

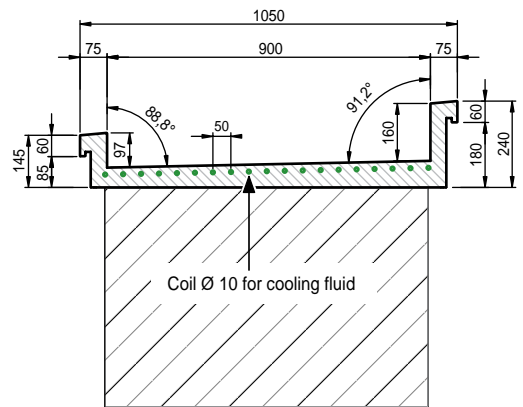

Tank - Section B:B

TECHNICAL FEATURES	
Overall dimensions (mm)	1050x1175x1093h
Surface exposure (m <sup>2</sup> )	0,81
Cooling gas	R404A

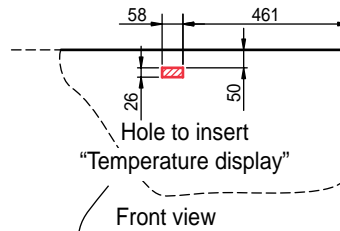

Front view

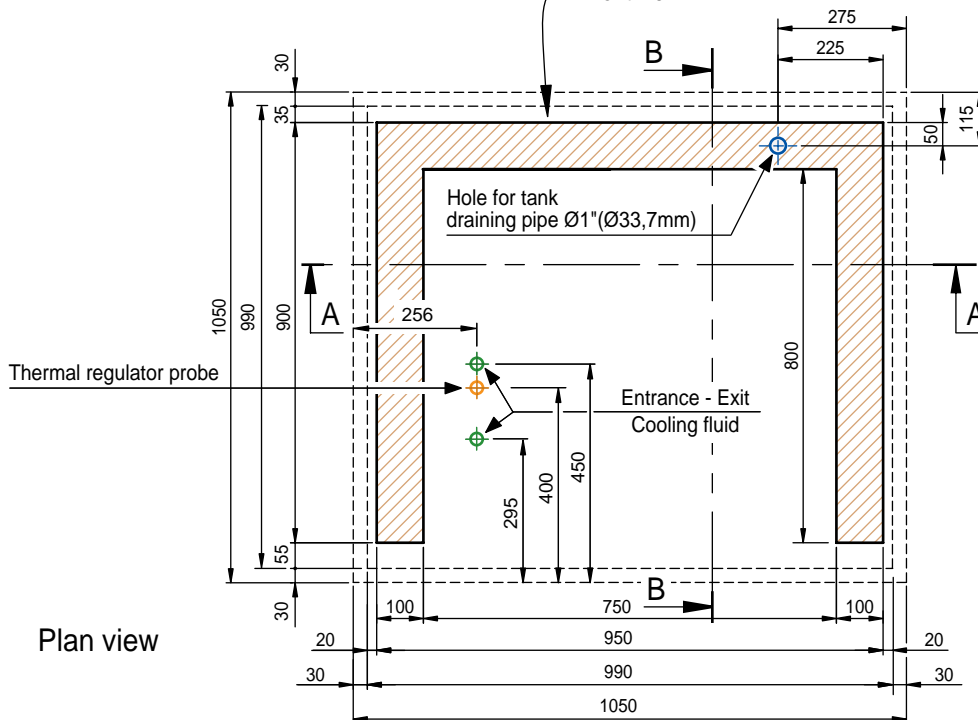

Plan view

FISH COUNTER 690 - VP 105 PV

Tank made of AISI 316 scotch-brite stainless steel with 31 mm drainage hole (3/4") supplied with internal high density polyurethane foam insulation complete with removable perforated false bottom made of stainless steel. The tank is supplied with electronic digital thermometer, with a temperature display positioned on the public side. The protection on the public side is characterized by tempered glass and by shockproof bar made of stainless steel. At the sides the tank is protected by two AISI 316 stainless steel shaped edges.

**Bendoniinox**

BENDONI INOX S.r.l.

I-52010 Bibbiena (Arezzo) - Fraz. Soci - Via S.Marco, 9

Phone: +39.0575.560.231 - Fax: +39.0575.561.362

Mail: [info@bendoni.it](mailto:info@bendoni.it) Web: [www.bendoni.it](http://www.bendoni.it)

Issued:

30/05/2008

Update:

0

Sheet 1 of 1

Il contenuto di questo disegno è di proprietà della Bendoni Innox s.r.l. e proibita la duplicazione senza la dovuta autorizzazione da parte della Bendoni Innox s.r.l. - Proprietario and confidential information contained in this drawing is the sole property of Bendoni Innox s.r.l. any without the written permission of Bendoni Innox s.r.l. is prohibited.